

MCT-231

Code-Secure™ Pendant Transmitter



Visonic

Installation Instructions

1. INTRODUCTION

The MCT-231 is a miniature pendant transmitter, designed for alarm and remote control applications. When activated, the transmitter sends out a Code Secure™ digital sequence identifiable by compatible Code Secure™ receivers. Each transmission comprises a digital sequence that differs from the one used in the previous transmission and which only the target receiver can recognize. "Code grabbing" is therefore not possible. Transmission is initiated by depressing the pushbutton at the center of the unit. Operating power is obtained from a coin-type, 3-volt lithium battery that can last up to 10 years.

An LED lights during transmission, indicating that the battery voltage exceeds 2.4 V. If the LED flashes during transmission, the battery must be replaced immediately. In addition, a "low battery" report will be transmitted with the outgoing digital message. Compatible receivers are designed to identify this report and operate a corresponding output.

All MCT-231 units are supplied with the chain installed, to be worn around the neck as pendant transmitters. A key ring is also included in the package, for use in place of the chain.

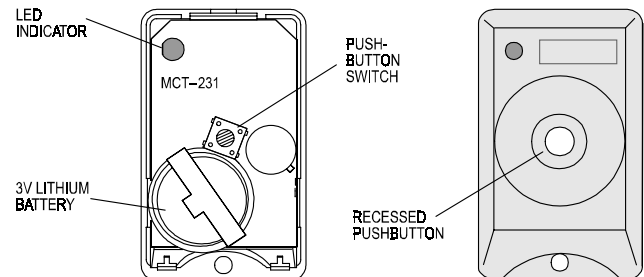

Figure 1. MCT-231 with Cover Removed

2. SPECIFICATIONS

Frequency (MHz): 315, 404, 433.92, 869.2625 or other frequencies according to local requirements.

Modulation: ASK (ON-OFF keying)

Transmitter ID: 28-bit digital word, Code Secure™

Power Supply: 3-volt Lithium cell (Toshiba type or equivalent).

Nominal Battery Capacity: 220 mAh

Battery Life Expectancy: 3 years (for typical use)

Battery Supervision:

Good battery - LED lights steadily upon activation.

Low battery - LED flashes upon activation.

Note: If transmission is still possible despite the battery condition, the MCT-231 will send a low battery report to the receiver.

Operating Temperature: 0° to 50°C (32° to 122°F).

Dimensions: 32 x 53 x 17 mm (1-1/4 x 2-1/8 x 11/16 in.).

Weight: 18 g (0.65 oz).

Color: White

Compliance with Standards: Meets FCC part 15, MPT 1340 and Directive 1000/5/EC

This device complies with Part 15 of the FCC Rules and RSS-210 of Industry and Science Canada. Operation is subject to the following two conditions: (1) This device may not cause harmful interference, and (2) this device must accept any interference received, including interference that may cause undesired operation.

This device complies with the essential requirements and provisions of Directive 1999/5/EC of the European Parliament and of the Council of 9 March 1999 on radio and telecommunications terminal equipment.

3. TESTING AND MAINTENANCE

3.1 Testing a New Unit

Since the MCT-231 is supplied with the battery already installed, the unit is practically ready to be tested.

- "Teach" the target receiver the ID code of the tested transmitter, as instructed in the target receiver's installation manual.
- Stand 3 m (10 ft) away from a target receiver and operate the MCT-231 by depressing its transmit pushbutton. Verify that the transmitter LED lights, indicating good battery condition.
- Observe that the receiver's LED lights steadily, and make sure that the controlled circuit reacts as programmed.
- Operate the transmitter from various locations within the area covered by the target receiver to determine "dead" locations, where transmission is blocked by walls and large objects, or affected by structural materials.

Note: If dead/marginal zones are a problem, relocating the receiver may improve the performance.

3.2 Battery Life

The original battery supplied with the transmitter can last up to 10 years if used sparingly (only a single transmission per day).

Battery replacement will therefore be needed very rarely. To replace the battery proceed as in 3.3, 3.4, 3.5, below.

3.3 Opening the Case

- To open the case, refer to Figure 2. Insert an 1/8 inch screwdriver blade in the slot at the bottom of the case. Press the blade inward, applying moderate pressure, and while pressing, swing the handle slightly down until the covers partially separate.

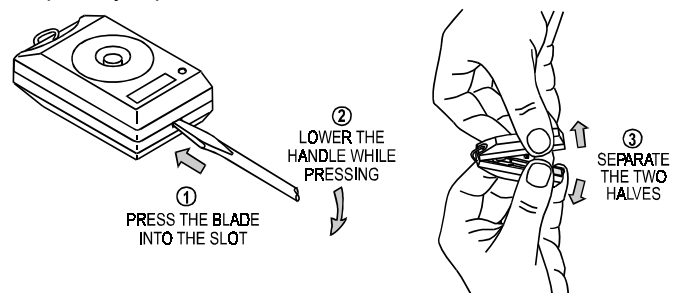

Figure 2. Opening the Case

Warning! Do not try to open the case by inserting a screwdriver in places other than the slot. This can damage the transmitter.

- B. Gently complete separation of the front and back covers with your fingers.

3.4 Replacing the Battery

- A. Grasp the transmit switch and lift the transmitter module out of the base.
 B. Slide the old battery from under the clip in the direction shown by the arrow in Figure 3.

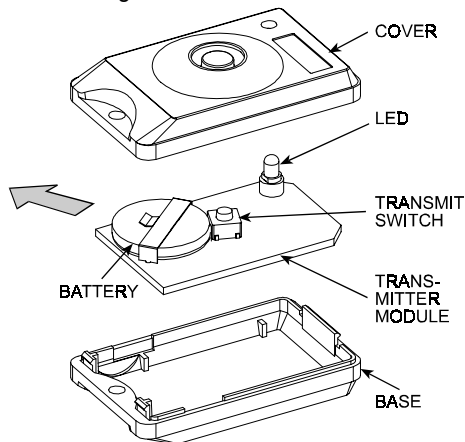

Figure 3. Battery Replacement

- C. Hold the 3-volt replacement battery (type CR-2032 or equivalent) with the positive (+) side up. Slide the battery all the way in under the battery clip until it stops.
 D. Briefly press the transmit switch (Fig. 3). The on-board LED should light brightly for 2 seconds.
 E. Place the module within the base. Then close the case as instructed in Para. 3.5 below.

3.5 Closing the Case

Carefully engage the ridges at the top of the rear cover with the dents at the top of the front cover. Gently press together the bottom ends of both covers, until they snap shut.

3.6 Keyring Installation

- A. Remove the chain by opening and slipping it through the triangle on top of the MCT-231.
 B. Insert the tip of a long-nose pliers into the triangle and open it.
 C. Remove the triangle.
 D. Open the plastic bag which contains the key-ring kit.
 E. Slip the key-ring triangle through the last link of the keying chain and install the triangle into the hole on the top of the MCT-231 (Fig. 4).
 F. Using the pliers, close the key-ring triangle.

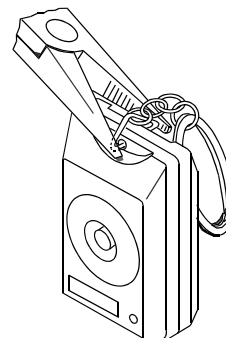

Figure 4. Keyring Installation

4. GENERAL COMMENTS

Our wireless systems are very reliable and are tested to high standards. However, due to their low transmitting power (required by FCC, DTI and other regulatory authorities) there are some limitations to be considered:

- A. Receivers may be blocked by radio signals occurring on or near their operating frequencies, regardless of the code selected.
 B. A receiver can only respond to one transmitted signal at a time.
 C. Wireless equipment should be tested regularly (at least once a week) to determine if there are sources of interference and to protect against faults.

WARNING: Changes or modifications to this unit not expressly approved by the party responsible for compliance could void the user's authority to operate the equipment.

WARRANTY

Visonic Ltd. and/or its subsidiaries and its affiliates ("the Manufacturer") warrants its products hereinafter referred to as "the Product" or "Products" to be in conformance with its own plans and specifications and to be free of defects in materials and workmanship under normal use and service for a period of twelve months from the date of shipment by the Manufacturer. The Manufacturer's obligations shall be limited within the warranty period, at its option, to repair or replace the product or any part thereof. The Manufacturer shall not be responsible for dismantling and/or reinstallation charges. To exercise the warranty the product must be returned to the Manufacturer freight prepaid and insured.

This warranty does not apply in the following cases: improper installation, misuse, failure to follow installation and operating instructions, alteration, abuse, accident or tampering, and repair by anyone other than the Manufacturer.

This warranty is exclusive and expressly in lieu of all other warranties, obligations or liabilities, whether written, oral, express or implied, including any warranty of merchantability or fitness for a particular purpose, or otherwise. In no case shall the Manufacturer be liable to anyone for any consequential or incidental damages for breach of this warranty or any other warranties whatsoever, as aforesaid.

This warranty shall not be modified, varied or extended, and the Manufacturer does not authorize any person to act on its behalf in the modification, variation or extension of this warranty. This warranty shall apply to the Product only. All products, accessories or attachments of others used in conjunction with the Product, including batteries, shall be covered solely by their own warranty, if any. The Manufacturer shall not be liable for any damage or loss whatsoever, whether directly, indirectly, incidentally, consequentially or otherwise, caused by the malfunction of the Product due to products, accessories, or attachments of others, including batteries, used in conjunction with the Products.

The Manufacturer does not represent that its Product may not be compromised and/or circumvented, or that the Product will prevent any death, personal and/or bodily injury and/or damage to property resulting from burglary, robbery, fire or otherwise, or that the Product will in all cases provide adequate warning or protection. User understands that a properly installed and maintained alarm may only reduce the risk of events such as burglary, robbery, and fire without warning, but it is not insurance or a guarantee that such will not occur or that there will be no death, personal damage and/or damage to property as a result.

The Manufacturer shall have no liability for any death, personal and/or bodily injury and/or damage to property or other loss whether direct, indirect, incidental, consequential or otherwise, based on a claim that the Product failed to function. However, if the Manufacturer is held liable, whether directly or indirectly, for any loss or damage arising under this limited warranty or otherwise, regardless of cause or origin, the Manufacturer's maximum liability shall not in any case exceed the purchase price of the Product, which shall be fixed as liquidated damages and not as a penalty, and shall be the complete and exclusive remedy against the Manufacturer.

Warning: The user should follow the installation and operation instructions and among other things test the Product and the whole system at least once a week. For various reasons, including, but not limited to, changes in environmental conditions, electric or electronic disruptions and tampering, the Product may not perform as expected. The user is advised to take all necessary precautions for his/her safety and the protection of his/her property.

6/91



VISONIC LTD. (ISRAEL): P.O.B 22020 TEL-AVIV 61220 ISRAEL. PHONE: (972-3) 645-6789, FAX: (972-3) 645-6788
 VISONIC INC. (U.S.A.): 10 NORTHWOOD DRIVE, BLOOMFIELD CT. 06002-1911. PHONE: (860) 243-0833, (800) 223-0020 FAX: (860) 242-8094
 VISONIC LTD. (UK): FRASER ROAD, PRIORY BUSINESS PARK, BEDFORD MK44 3WH. PHONE: (0870) 7300800 FAX: (0870) 7300801
 INTERNET: www.visonic.com

©VISONIC LTD. 2002 MCT-231 DE2361-(REV. 2, 7/02)

