

DUET-AM

Dual-Technology Microwave/PIR Intrusion Detector



Installation Instructions

1. FEATURES

- Combined Fresnel and cylindrical optics improves detection range and false alarm immunity.
- Look-down "creep zone" lens.
- **True Motion Recognition™ (TMR)** algorithm (patented) for recognition of true motion of a human body.
- DRO-stabilized MW microstrip technology.
- **MW Motion Simulator** simulates the effect of a human body moving in the MW field (patent pending for MW self-test).
- Range control for adjusting the MW coverage.
- PIR self-test by applying a short heat pulse.
- Temperature compensation for the PIR section.
- Unique tamper protection mechanism.

- Programmable motion event counter (1 or 2 events).
- Simple-to-use, three-position vertical adjustment.
- **TEST** input to enable/disable the walk test LED remotely (per new European standard).
- Relay output for trouble.
- Anti-masking protection.
- White light protection.
- Optional swivel brackets for wall or ceiling installation.

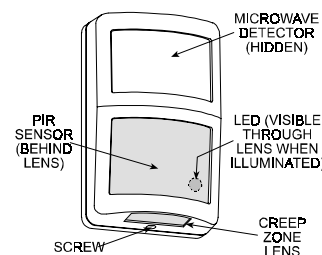

Figure 1. General View

2. SPECIFICATIONS

Input Voltage: 9 to 16 VDC

Current Drain @ 12 VDC: 21 mA standby, 29 mA max.

PIR SECTION

Sensor: Low noise dual-element pyroelectric type

Tripping Indication: LED flashes green for up to 5 seconds

Motion Event Verification Counter: Selectable, 1 or 2 events

Front Lens Data (see Figure 2)

Beams: 32 in two layers (10 curtain beams in bottom layer)

Max. Coverage: 20 x 20 m (60 x 60 ft) / 90° field of view

Vertical Adjustment: FAR, MID and NEAR, by sliding the circuit board along a 3-position scale.

MW SECTION

Oscillator: Microstrip DRO-stabilized Doppler sensor

Frequency: 10.687 GHz (in the UK only) or 10.525 GHz

Detection Range: Adjustable from 25% to 100% (5 m to 20 m)

Tripping Indication: LED lights green for up to 5 seconds

ALARM, TAMPER & TROUBLE DATA

Alarm Indication: LED lights red for 1.3 to 5 seconds if both sensors trip

Alarm Relay: Solid state, N.C., 0.1 A resistive / 30 VDC; 35 Ω max. internal resistance

Alarm Duration: 1.3 to 5 seconds

Tamper Switch: N.C., rated at 50 mA resistive / 30 VDC

Trouble Relay: Solid state, N.C., 0.1 A resistive / 30 VDC; 35 Ω max. internal resistance

Masking Detection Delay: About 60 seconds

Trouble/ Masking Indication: LED alternately flashes green and red and TRB relay opens until the detector is reset.

MOUNTING

Form: Surface or corner (no brackets); surface, corner and ceiling with brackets

Height: 2 - 2.6 m (6.5 - 8.5 ft) without bracket, 2 - 3.6 m (6.5 - 12 ft) with bracket.

Caution: with brackets in use, effective detection ranges may differ from those indicated in Figures 2 and 8.

Optional Brackets: BR-1 (surface), BR-2 (corner) and BR-3 (ceiling).

ENVIRONMENTAL

RFI Protection: >30 V/m up to 1000 MHz.

Operating Temperatures: -10°C to 50°C (14°F to 122°F).

Storage Temperatures: -20°C to 60°C (-4°F to 140°F).

Standards: Complies with Part 15 of the FCC Rules.

This device complies with the essential requirements and provisions of Directive 1999/5/EC of the European Parliament and of the Council of 9 March 1999 on radio and telecommunications terminal equipment.

PHYSICAL

Dimensions (H X W X D): 123 x 76 x 48 mm (4-13/16 x 3 x 1-7/8 in.)

Weight: 145 g (4.5 oz).

PATENTS

U.S. Patents 5,237,330 and 5,693,943

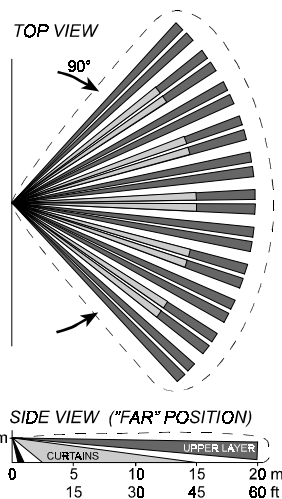
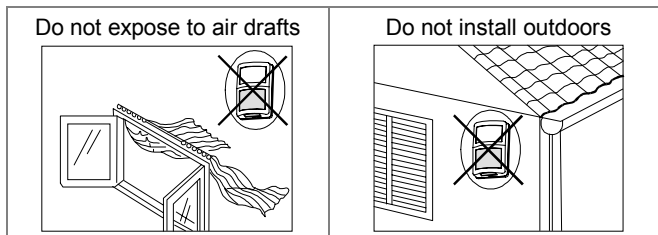
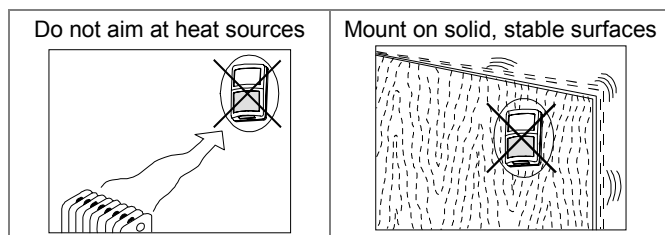

Figure 2. Coverage Pattern

3. INSTALLATION

3.1 Installation Tips

To minimize false alarms:



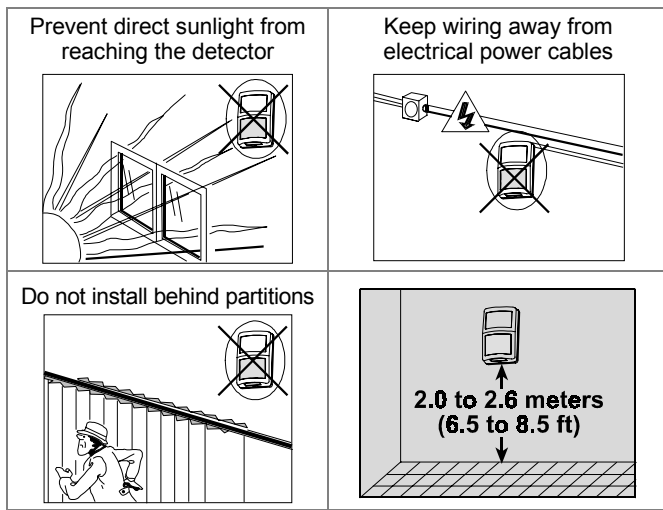

In addition, a few important rules must be observed while selecting a mounting location:

- A. Microwave radiation passes through glass and non-metallic walls. Be sure to adjust the MW range so that it does not exceed the room limits, or else motion in the next room or moving traffic along the outer side of the wall will cause the MW sensor to trip.
- B. Large reflecting objects (especially metals) in the coverage area can distort the microwave sensor's coverage pattern.
- C. If two DUET-AM units are installed in the same room or on opposite sides of a shared wall, they should not face each other and must be mounted at least 2 meters apart.
- D. Do not install the DUET-AM in places where one of the two sensor circuits alarms constantly or intermittently, due to environmental interference.
- E. **DUET-AM users are advised to mount the unit in locations where inadvertent approach to less than 1 m (3 ft) from the detector is unlikely to occur.**

3.2 Mounting

A. Remove the front cover as shown in Figure 3.

IMPORTANT: When re-mounting the cover, remember to fasten the screw well - this will force the tamper switch actuator upon the tamper switch and will press it fully in.

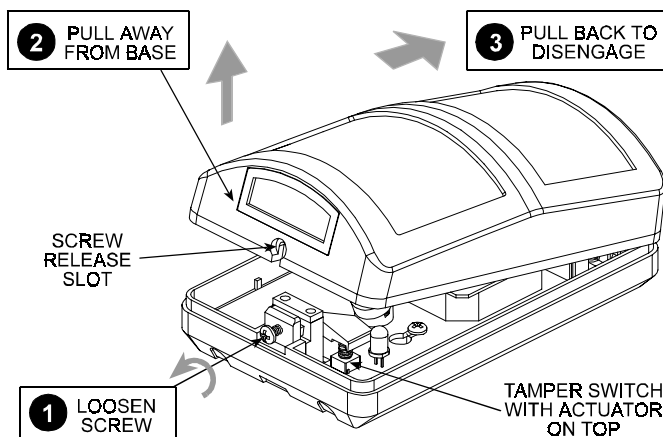

Figure 3. Cover Removal

- B. Loosen the vertical adjustment screw, slide the PCB up and remove it via the "keyhole" (see Figure 4).
- C. Put the PCB aside until required again.
- D. Refer to Figure 5 and punch out the mounting knockouts at the rear of the base (for surface mounting) or at the angled sides (for corner mounting).
- E. Punch out any one of the wiring knockouts shown in Figure 5.
- F. Hold the base against the wall at the selected installation location, mark the points for drilling and drill the holes. Insert the plastic dowels (supplied) if necessary.
- G. Pass the wires through the wiring inlets into the base and attach the base to the wall using the screws (supplied).

- H. Return the PCB to its place within the base.
- I. Proceed to wire the terminal block as instructed in Para. 3.3.

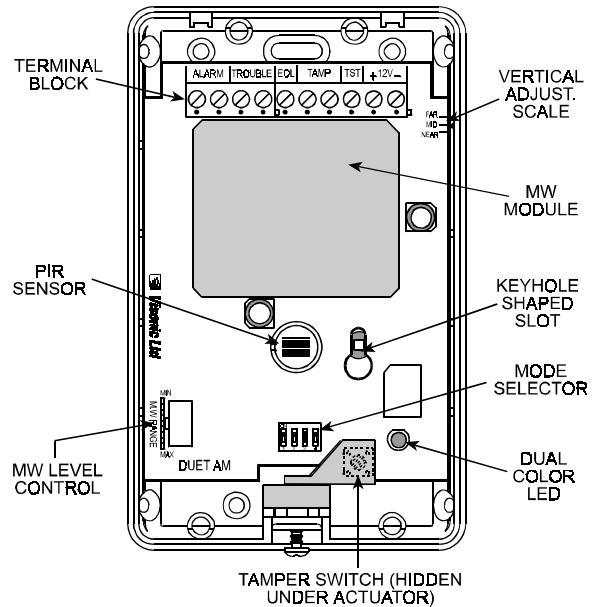

Figure 4. PCB Layout

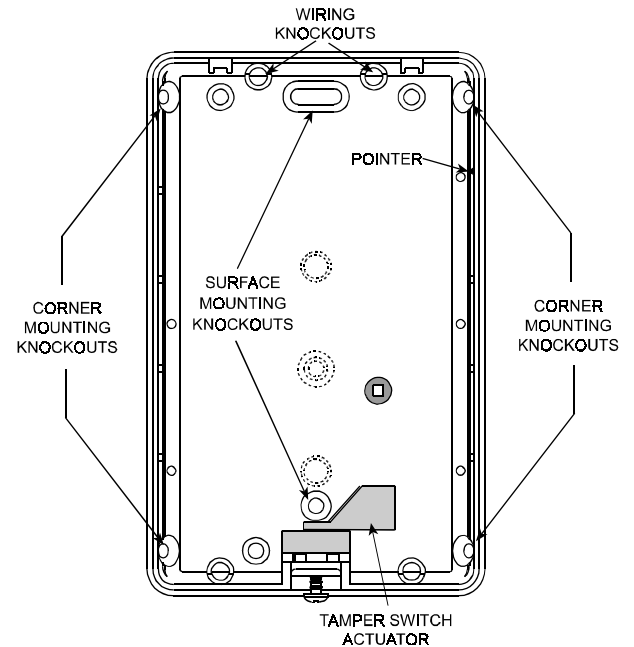

Figure 5. Base after PCB Removal

3.3 Wiring

Refer to Figure 6 and wire up the terminal block:

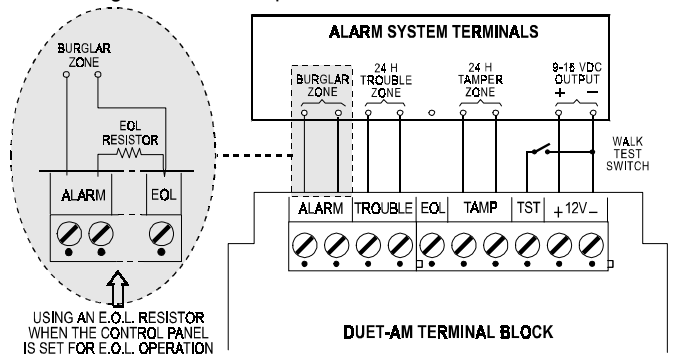

Figure 6. Terminal Block Wiring

IMPORTANT: To comply with CE safety requirements, connect to CE-approved control panels with current-limited DC output.

Note: Use RTV to seal the base opening(s) to prevent insects from entering the detector.

TST INPUT LOGIC

The dual color LED may be enabled remotely for walk testing with a test switch connected to the TST input as shown in Figure 6:

TST input grounded - LED active

TST input floating or high (+12V) - LED inactive (unless mode switch 2 is ON).

3.4 The Power-up Process

After connecting the (+) and (-) terminals to the power source, the DUET-AM starts a 60-second warm-up period, indicated by alternate flashing of the green and red lights.

Caution! If the alternate flashing of the red and green lights does not stop within 60 seconds, a failure has been detected by the self-test circuitry or, if mode switch 3 is set to ON, the unit may be masked (refer to Para. 3.5).

3.5 What Happens in Case of Masking?

Attention! The following procedure is true only while mode switch 3 is in the ON position.

If an attempt is made to stick masking material over the lens or put a masking object close to the lens, a trouble alert will result about 60 seconds after masking:

- The LED will flash red and green alternately;
- The TRB relay will open and will remain so until masking is removed and the detector is reset (see Para. 3.13 for procedure).

3.6 Visual Indications

The dual color LED is used to signal various alarm and trouble messages as shown in Table 1 below:

Table 1. Interpreting the Visual Indications

Visual Indication	Significance
None	No detection
Steady green (5 seconds)	MW walk-test detection
Flashing green	PIR walk-test detection
Steady red (5 seconds)	Alarm: MW + PIR detection
Flashing red and green (alternately)	- Trouble is being detected (or masking if mode switch 3 is ON) - Initial warm-up routine (stops 60 seconds after power up).

Notes:

1. During walk testing, the green light glows steadily (MW detection) or flashes (PIR detection), depending on which one of the two sensors discovered the movement first. Upon subsequent discovery of the movement by the other sensor, the green light goes off and the red light glows (alarm).
2. If the LED maintains alternate red and green flashing beyond the warm-up period, a malfunction has been diagnosed (or, if mode switch 3 is ON, the detector may be masked).

3.7 Mode Selector

The DIP switch mode selector is mounted on the unit's PC board (see Figure 4). It controls four functions as demonstrated in Figure 7.

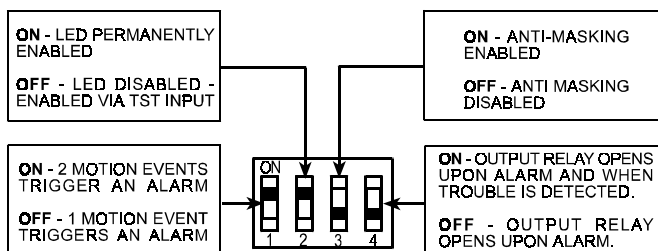

NOTE: SWITCH POSITIONS SHOWN ARE FACTORY DEFAULTS

Figure 7. DIP Switch Mode Selector

3.8 Vertical Adjustment

The vertical adjustment scale for the PIR sensor is located at the upper right edge of the PC board (refer to Figure 4). Three positions are available - FAR, MID and NEAR. All new DUET-AM units are set to the FAR position. To adjust, loosen the vertical adjustment screw, slide the PC board along the vertical slot until the pointer indicates the required position on the scale (see Figure 8). When done, tighten the adjustment screw firmly.

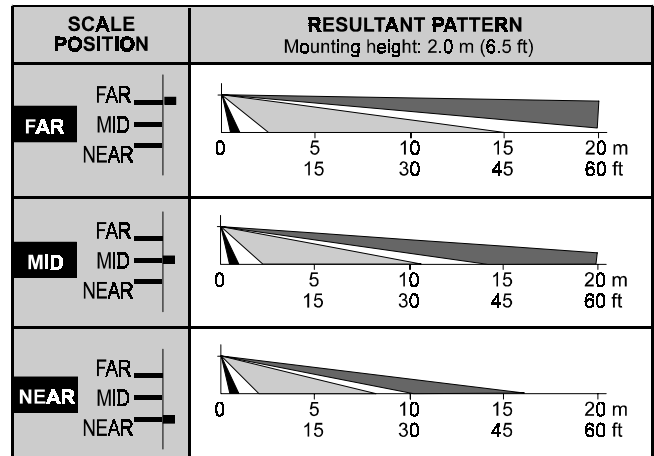

Figure 8. Vertical Adjustment

Caution! With swivel brackets in use, the effective detection ranges may differ from those indicated in Figures 2 and 8.

3.9 Setting the Motion Event Counter

If you wish to set the PIR sensor for maximum false alarm immunity, shift DIP switch No. 1 (SW-1) to ON. In this position, two consecutive motion events are required to trip the PIR sensor. For faster catch performance, shift SW-1 to OFF. In this position, only one motion event is required to trip the PIR sensor.

3.10 PIR Walk Test

- A. Rotate the MW RANGE control fully counterclockwise to MIN.
- B. Make sure that the LED is enabled, either by setting mode switch SW-2 to ON or by grounding the TST input.
- C. Mount the front cover in place.
- D. Walk into the detector's field of view at the expected far edge of the coverage area. The green light should flash for up to 5 seconds each time your motion is detected.

Note: If the LED lights green steadily for up to 5 seconds, your motion has been detected by the MW sensor.

- E. If PIR detection is not obtained at the far end of the coverage area, remove the front cover and re-adjust the vertical position. Replace the cover and retest.

3.11 MW Walk Test

- A. Remove the front cover.
- B. Verify that the MW RANGE control is set fully counterclockwise to MIN and enable the LED either by setting mode switch SW-2 to ON or by grounding the TST input.
- C. Start by moving into the coverage area at the far edge. The LED should light green for up to 5 seconds each time your motion is detected.
- D. If your motion was not detected at the far edge, advance the MW RANGE control slightly clockwise toward MAX and try again until your motion is detected reliably at the far edge.

Caution! The MW detection range must not exceed the far edge of the desired coverage area.

- E. Walk across the coverage area at various ranges and verify that your motion is consistently detected.

3.12 Alarm Walk Test

- A. Make sure that the LED is enabled, either by setting mode switch SW-2 to ON or by grounding the TST input.
- B. Install the front cover in place.
- C. Walk across the detector's field of view in different directions, at various distances from the detector, and verify proper

alarming throughout the detector's coverage area (the LED lights red for 1.3 to 5 seconds).

- D. When done, disable the LED by setting set switch SW-2 to OFF or by disconnecting the TST input (leaving it "floating").
- E. Remount the cover and fasten it to the base using the small screw at the bottom.

Attention! To assure proper function of the detector, the range and coverage area should be checked at least twice a year. Furthermore, it is recommended that users perform a walk test at the far end of the coverage pattern to assure an alarm signal prior to each time the alarm system is armed.

4. MISCELLANEOUS COMMENTS

This device has been tested and found to comply with the limits for a Class B digital device, pursuant to Part 15 of the FCC Rules. These limits are designed to provide reasonable protection against harmful interference in residential installations. This equipment generates, uses and can radiate radio frequency energy and, if not installed and used in accordance with the instructions, may cause harmful interference to radio and television reception. However, there is no guarantee that interference will not occur in a particular installation. If

3.13 Resetting after Trouble

If trouble occurs while **mode switch 3 is ON**, proceed as follows:

- Search for masking material on the lens or a masking object in front of the lens and remove them, if found.
- Reset the detector by walk testing: cross its field of view at the far end, causing it to alarm several times.

If everything is back to normal, the LED should stop flashing, and the TRB relay should revert to the closed circuit state.

Note: If walk testing does not cause the trouble alert to stop and **mode switch 3 is ON**, recheck for masking. Once masking is ruled out, the trouble must be due to faulty PIR or MW circuitry.

this device does cause such interference, which can be verified by turning the device off and on, the user is encouraged to eliminate the interference by one or more of the following measures:

- Re-orient or re-locate the receiving antenna.
- Increase the distance between the device and the receiver.
- Connect the device to an outlet on a circuit different from the one which supplies power to the receiver.
- Consult the dealer or an experienced radio/TV technician.

WARRANTY

Visonic Ltd. and/or its subsidiaries and its affiliates ("the Manufacturer") warrants its products hereinafter referred to as "the Product" or "Products" to be in conformance with its own plans and specifications and to be free of defects in materials and workmanship under normal use and service for a period of twelve months from the date of shipment by the Manufacturer. The Manufacturer's obligations shall be limited within the warranty period, at its option, to repair or replace the product or any part thereof. The Manufacturer shall not be responsible for dismantling and/or reinstallation charges. To exercise the warranty the product must be returned to the Manufacturer freight prepaid and insured.

This warranty does not apply in the following cases: improper installation, misuse, failure to follow installation and operating instructions, alteration, abuse, accident or tampering, and repair by anyone other than the Manufacturer.

This warranty is exclusive and expressly in lieu of all other warranties, obligations or liabilities, whether written, oral, express or implied, including any warranty of merchantability or fitness for a particular purpose, or otherwise. In no case shall the Manufacturer be liable to anyone for any consequential or incidental damages for breach of this warranty or any other warranties whatsoever, as aforesaid.

This warranty shall not be modified, varied or extended, and the Manufacturer does not authorize any person to act on its behalf in the modification, variation or extension of this warranty. This warranty shall apply to the Product only. All products, accessories or attachments of others used in conjunction with the Product, including batteries, shall be covered solely by their own warranty, if any. The Manufacturer shall not be liable for any damage or loss whatsoever, whether directly, indirectly, incidentally, consequentially or otherwise, caused by the malfunction of the Product due to products, accessories, or attachments of others, including batteries, used in conjunction with the Products.

The Manufacturer does not represent that its Product may not be compromised and/or circumvented, or that the Product will prevent any death, personal and/or bodily injury and/or damage to property resulting from burglary, robbery, fire or otherwise, or that the Product will in all cases provide adequate warning or protection. User understands that a properly installed and maintained alarm may only reduce the risk of events such as burglary, robbery, and fire without warning, but it is not insurance or a guarantee that such will not occur or that there will be no death, personal damage and/or damage to property as a result.

The Manufacturer shall have no liability for any death, personal and/or bodily injury and/or damage to property or other loss whether direct, indirect, incidental, consequential or otherwise, based on a claim that the Product failed to function. However, if the Manufacturer is held liable, whether directly or indirectly, for any loss or damage arising under this limited warranty or otherwise, regardless of cause or origin, the Manufacturer's maximum liability shall not in any case exceed the purchase price of the Product, which shall be fixed as liquidated damages and not as a penalty, and shall be the complete and exclusive remedy against the Manufacturer.

Warning: The user should follow the installation and operation instructions and among other things test the Product and the whole system at least once a week. For various reasons, including, but not limited to, changes in environmental conditions, electric or electronic disruptions and tampering, the Product may not perform as expected. The user is advised to take all necessary precautions for his/her safety and the protection of his/her property.

6/91



VISONIC LTD. (ISRAEL): P.O.B 22020 TEL-AVIV 61220 ISRAEL. PHONE: (972-3) 645-6789, FAX: (972-3) 645-6788

VISONIC INC. (U.S.A.): 10 NORTHWOOD DRIVE, BLOOMFIELD CT. 06002-1911. PHONE: (860) 243-0833, (800) 223-0020 FAX: (860) 242-8094

VISONIC LTD. (UK): UNIT 1, STRATTON PARK, DUNTON LANE, BIGGLESWADE, BEDS. SG18 8QS. PHONE: (01767) 600857 FAX: (01767) 601098

INTERNET: www.visonic.com

©VISONIC LTD. 2001 DUET-AM DE1812- (REV. 0, 7/01)



MADE IN ISRAEL