

MCPIR-2000

Fully Supervised PowerCode Wireless PIR Detector



Visonic

Installation Instructions

1. INTRODUCTION

The MCPIR-2000 is an advanced, fully supervised ultra low-current wireless PIR that incorporates a PowerCode transmitter. Both transmitter and detector circuits are powered by an on-board, long life 3.6 V Lithium battery.

Each MCPIR-2000 unit has a 24-bit ID code, randomly selected in the factory from over 16 million possible combinations. This code is therefore unique and virtually impossible to reproduce. Compatible PowerCode receivers are designed to "learn" specific IDs and respond only to them.

Following detection, the MCPIR-2000 triggers the on-board transmitter which transmits its specific PowerCode ID followed by an Alarm signal and status designators for Tampering and Battery Condition. Alarm and other data are thus forwarded to the alarm control panel or to a head-end computer, depending on the type of system in which the detector is used.

Since messages transmitted by the MCPIR-2000 might collide with messages transmitted by other PowerCode transmitters, a "smart" anti-collision transmission sequence is used.

A periodic supervision message, distinguished by a specific marker, is transmitted automatically once in 60 min. (USA) or 15 min. (Europe) or according to local standards. The receiver is thus informed, that the particular detector is taking an active part in the wireless network.

After triggering the transmitter, the MCPIR-2000 disarms itself to save battery power. The detector rearms itself automatically (reverts to the ready state) 2 minutes after the last movement has been detected. A LED/ WALK-TEST selector is used to override the 2-minute rearm timer during walk testing.

A programmable pulse counter is included in the unit for maximum immunity against false alarms.

An entire library of interchangeable lenses, 25° vertical and 30° horizontal adjustment, surface, corner or flush mounting installation from 0 to 17 feet height, all these features enhance the detector's versatility of application and make it a worthwhile unit to standardize on.

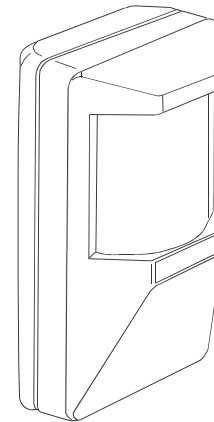

Figure 1. General View

Visonic Ltd.'s "SUPER-RED" lens library provides a variety of 45 easy-to-change lens selection and coverage patterns and includes:

- 9 wide-angle lenses up to 140°
- 3 long-range corridors up to 36 m (120 ft.)
- 6 pet alleys
- 3 finger curtains
- 8 lenses for combined ceiling and room coverage
- 10 lenses for 2-3 room and corridor coverage

2. SPECIFICATIONS

OPTICAL

Standard Lens: No. 100 (see Figure 2), 36 beams, 3 layers.

Upper Layer - 9 twin beams, optically split to 18 beams.

Intermediate Layer - 5 twin beams, 10° below upper layer.

Downward Layer - 4 twin beams, angled 25°_i below upper layer.

Field of View: 90°_i wide angle.

Coverage range: Maximum 18 x 18 m (60 x 60 ft).

Interchangeable Lenses: See SUPER-RED Lens Library.

Adjustment: Vertical +10° to -15°, Horizontal up to 30°.

ELECTRICAL

Battery Type: 3.6 Volt lithium thionyl chloride (LiSOCl₂) battery, size 1/2AA, Tadiran TL-5902.

Battery Capacity: 1.2 Ah nominal

Standby Current: 0.015 mA.

Transmit Current Drain: 9.5 mA (including LED)

Battery Life Expectancy: 3 years (for typical use)

LED: Lights for 2 seconds upon transmission and upon motion detection in the walk test mode.

Detector: Dual-element low-noise pyroelectric sensor.

Pulse Counter: Programmable to 1, 3 or 5 pulses.

Maximum Coverage: 18 x 18 m/90°
(60 x 60 ft/90°)

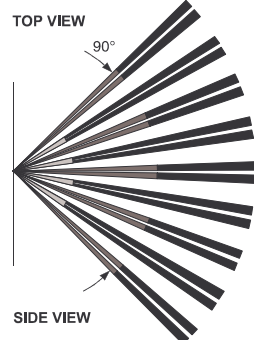

Figure 2. Coverage Pattern - Lens No. 100

Rearm Timer: 2 minutes after the last alarm; timer disabled in the walk test mode.

WIRELESS

Frequency (MHz): 315, 433.92 or other frequencies according to local requirements.

Transmission Sequence: 3 data bursts at variable intervals within 3 seconds.

Encoding: 24-bit factory selected ID code, over 16 million possible combinations.

Message Length: 36 bits

Battery Supervision: Automatic reporting of battery status with each alarm and with periodic autotest.

Tamper Alert: Reported at 3-minute intervals, until the tamper switch is restored

ENVIRONMENTAL

Operating Temperature: -10° to 50°C (14° to 122°F).

Storage Temperature: -20° to 60°C (-4°F to 140°F).

RFI Protection: > 20 V/m up to 1000 MHz.

PHYSICAL

Weight: 105 g (3.7 oz).

Dimensions (H x W x D): 12 x 7 x 4.8 cm (4-3/4 x 2-3/4 x 1-7/8 in.)

Color: White.

Compliance with Standards: FCC Part 15, ETS300-220 and MPT1349

OPTIONAL MOUNTING ACCESSORIES

SRF-201: Flush mounting adapter.

SRS-202: Mounting stand for portable applications.

BR-1: Swivel bracket for wall mounting.

BR-2: BR-1 + corner mounting adapter.

BR-3: BR-1 + ceiling mounting adapter.

3. INSTALLATION

3.1 Removing / Remounting the Cover

- A. Insert a small screwdriver into the slot on top of the unit (Figure 3). Press the blade in between the cover and the base, then push downwards and lever backwards. The top part of the cover (equipped with the lens) will snap free. You may now hinge the top of the cover outward, separate the bottom legs of the base from the slots in the cover and remove the cover.
- B. To remount the cover, insert the legs at the bottom of the base into their respective slots in the bottom of the cover and close by exerting slight upward pressure (Figure 4).

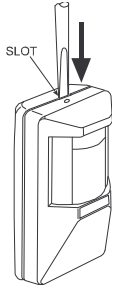

Figure 3. Removing the Cover

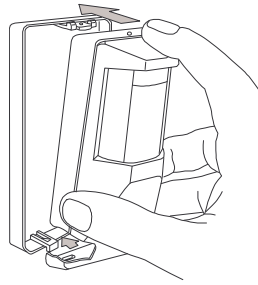

Figure 4. Remounting the cover

3.2 Changing Lenses

To change or adjust a lens, remove the front cover of the detector (para. 3.1).

Release and remove the lens retainers located on both sides of the lens by pushing them out from the inner side of the cover (Fig. 5).

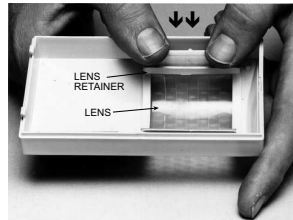

Figure 5. Removing the Lens Retainers

Insert a new lens with the smooth surface facing out and the lens number in the upper right corner (when looked at from the inner side of the cover).

Carefully center the lens by sliding it right or left. Holding the lens firmly in place, insert the lens retainers from the front (ridges pointed outward) and push them into place until a click is heard (see Fig. 6).

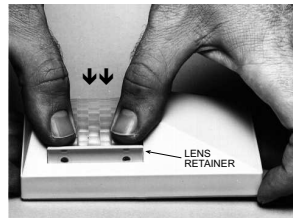

Figure 6. Locking the Lens

3.3 Inserting the Battery

Insert the battery as follows:

- A. Remove the detector's front cover as in Para. 3.1 and push the battery into the battery clip - observe polarity.
- B. Press the tamper switch lever once and release it. This will perform the reset necessary for smooth power up.
- C. Put the cover on and watch the LED. It will flash once in 2 seconds for at least 15 seconds until the sensor stabilizes.

3.4 Registration of the Transmitter ID in the Target Receiver's Memory

Refer to the target receiver's installation instructions and follow the procedure given there for "teaching" transmitter IDs. It is much easier to carry out this operation in close proximity to the receiver, before actually mounting the detector in place.

3.5 Selecting the Mounting Location

The MCPiR-2000 can be mounted directly onto the wall (surface mounted), or in a corner.

- A. Select the mounting location so that an intruder's motion will cross the beams of the selected pattern.
- B. Determine the convenient mounting height.

NOTE: The vertical calibration scale on the detector's printed circuit board is factory preset at -5° (see Table 1 for scale application).

- C. Where a single-layer pattern has been selected for pet avoidance, install the detector as low as possible, usually 1.2 - 1.5 m (4 - 4.5 ft) while still allowing the beams to be directed above the level of the pet's activity.
- D. To minimize false alarms, avoid aiming the detector at heaters, sources of bright light, or windows subjected to direct sunlight.
- E. Always mount the unit on a firm and stable surface.

3.6 Direct Mounting

Mount the base (equipped with the p.c. board) in the location and height selected for optimum coverage.

For surface mounting use the two knockouts at the back of the base; for corner mounting, use the knockouts on the angled sides (see Figure 7).

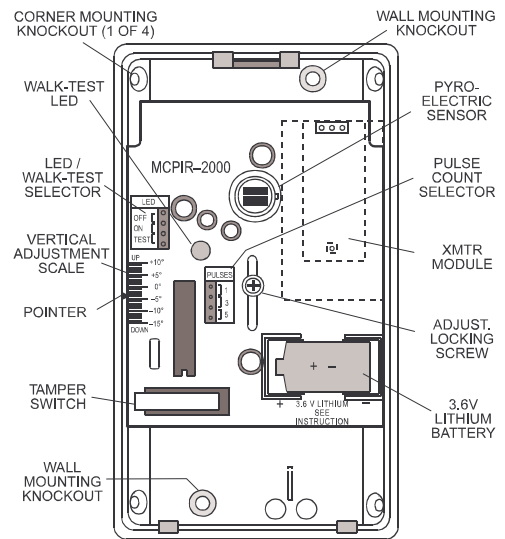

Figure 7. Components Layout

3.7 Adjusting the Coverage Area

Horizontal Adjustment

The coverage pattern can be adjusted horizontally $\pm 15^\circ$ by shifting the lens to the left or right. To adjust the lens, remove the lens retainers (see Para. 3.2), shift the lens carefully to the desired position and re-insert the lens retainers into their places.

Vertical Adjusting Scale

The vertical scale adjustment (printed on the left side of the p.c. board) and the plastic pointer on the base indicate (in degrees) the vertical angle between the upper layer of the coverage pattern and the horizontal line of the unit.

Table 1 gives the recommended scale adjustment of mounting heights and coverage distances. The scale enables pattern adjustment from $+10^\circ$ to -15° , according to the installation height and the required coverage range. Do not exceed the maximum range of the selected lens, as indicated in the lens library catalog.

Table 1. Vertical Adjusting Scale

Mounting Height	Coverage Range															
	7	10	13	17	20	23	26	30	33	40	50	60	80	100		
ft	2	3	4	5	6	7	8	9	10	12	15	18	24	30		
m	0.6	1	1.2	1.5	1.8	2	2.5	3	3.6	4.2	5	6	8	10		
	+8°	+6°	+5°	+4°	+3°	+2°	+2°	+2°	+2°	+1°	+1°	0°	0°	0°		
	0°	0°	0°	0°	0°	0°	0°	0°	0°	0°	0°	0°	0°	0°		
	-8°	-6°	-5°	-4°	-3°	-2°	-2°	-2°	-2°	-1°	-1°	-1°	0°	0°		
	-	-12°	-9°	-7°	-6°	-5°	-5°	-4°	-4°	-3°	-2°	-2°	-1°	-1°		
	-	-	-14°	-11°	-9°	-8°	-7°	-6°	-5°	-5°	-4°	-3°	-2°	-2°		
	-	-	-	-13°	-12°	-10°	-9°	-8°	-7°	-6°	-5°	-4°	-3°	-2°		
	-	-	-	-	-15°	-13°	-11°	-10°	-9°	-7°	-6°	-5°	-4°	-3°		
	-	-	-	-	-	-	-	-14°	-12°	-10°	-9°	-7°	-5°	-4°		
	-	-	-	-	-	-	-	-	-15°	-12°	-10°	-8°	-7°	-5°		
	-	-	-	-	-	-	-	-	-	-15°	-13°	-10°	-8°	-6°		
	-	-	-	-	-	-	-	-	-	-	-	-14°	-10°	-8°		

Example: If you require coverage range of 40 ft (12 m) and wish to install the sensor at a height of 6 ft (1.8 m) from the ground, set the Vertical Adjustment Scale to -5°.

To change the vertical-pattern adjustment, loosen the screw to slide the PC board to the desired angle and then tighten the screw firmly.

Beam Masking Material

A special beam-masking material supplied with each detector can be used to mask individual segments in the lens array which are exposed to potential sources of false alarms (heaters, blowers, pets, etc). The material is transparent to visible light but blocks any infrared energy. To block individual beam(s), cut the masking material to the exact dimensions of the segment(s) to be blocked, remove the backing paper and apply the mask accurately to the inside (smooth) surface of the lens on these segment(s). In some cases, more than one layer may be required to completely block the infrared energy.

3.8 Setting the Pulse Counter

MCPIR-2000 detectors are equipped with a programmable pulse counter which can be set to count 1, 3 or 5 pulses, before activating the wireless transmitter. To set the pulse counter, place the jumper at the desired setting (1, 3 or 5 - see Fig. 8).

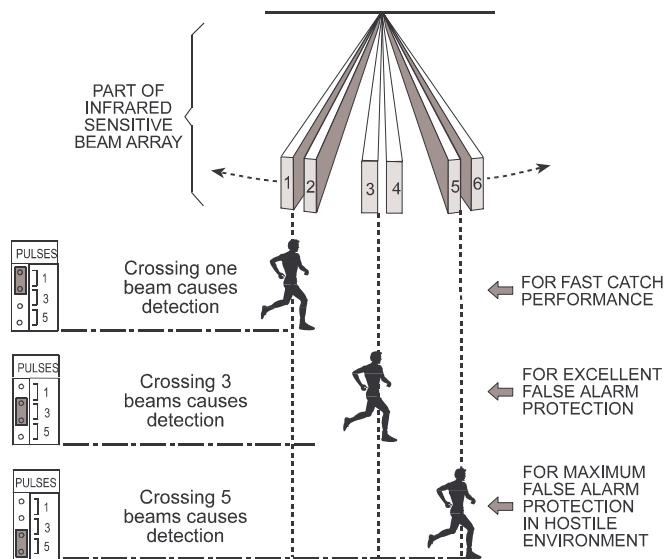

Figure 8. Setting the Pulse Counter

Note: Three pulses may be selected for all applications where wide-angle, multi-beam lenses are used, such as illustrated in Sections 1, 2, 3, 6 and 7 of the SUPER RED lens library.

Three pulses should never be used with lens No. 53 or with long-range lenses from Sections 4 & 5 of the Lens Library.

3.9 Walk Testing

IMPORTANT! The range and the coverage area of the unit should be checked at least once a year. To assure proper continuous functioning, the end user should be instructed to perform a walk test at the far end of the coverage pattern prior to each time the alarm system is armed.

To save battery power in normal use, an automatic timer inhibits the detector for approximately 2 minutes after transmitter activation. The detector is automatically rearmed 2 minutes after detection of the last motion.

For effective walk testing, it is necessary to override the 2 minute timer by setting the LED/WALK-TEST jumper to the TEST position as shown to the right.

Note: If the LED/walk-test jumper is forgotten in TST position, the detector returns to ON position after approximately 30 minutes, to save battery power.

IMPORTANT! Once the cover is replaced, the detector goes through a stabilization period. The LED will flash once per 2 seconds until the detector has stabilized (stabilization time is at least 15 seconds).

A. Walk-test the entire protected area by walking slowly across the detector's field of view, observing the LED. Pause for 5 seconds after each test to allow the unit to complete its 3-

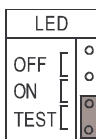

transmission sequence (see Para. A-2 in Appendix A). the LED will light for 2 seconds.

B. Set the LED/WALK-TEST jumper to the ON position as shown to the right.

Wait outside the coverage area. After five minutes, re-enter the coverage area and verify that the LED lights for 2 seconds upon detection.

C. If you continue moving, the unit will remain disabled due to the 2-minute battery saving timer. The unit will be rearmed provided that no motion is detected for approximately 2 minutes, and will then be ready to detect and transmit.

D. When done, set the LED/WALK-TEST jumper to the OFF position as shown to the right.

This setting is recommended to prevent unauthorized people from tracing the detector's coverage pattern.

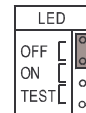
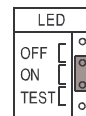

3.10 Optional Accessories

A. Swivel Brackets

The BR-1 is a swivel, surface-mount bracket which provides greater flexibility when setting the desired detection range. The BR-1 is adjustable 30° downward and 45° left or right (Fig. 9).

The BR-2 is a similar swivel bracket kit for room corners.

The BR-3 is a similar swivel bracket kit for ceilings installations.

ATTENTION: With optional swivel brackets in use, the effective detection range may differ from that indicated in Table 1.

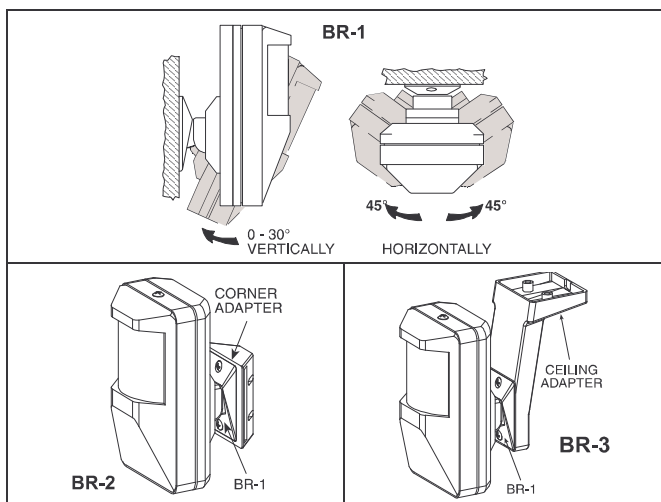

Figure 9. Optional Swivel Brackets

B Flush Mount Bracket

(Fig. 10)

If necessary, the MCPIR-2000 may be flush mounted, using the optional flush-mount bracket SRF-201.

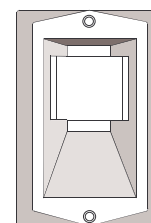

Figure 10. SRF-201

C. Mobile Stand (Fig. 11)

A special stand, the SRS-202, enables you to place the MCPIR-2000 detector temporarily on horizontal surfaces such as shelves, tables, etc. This accessory is especially suitable for portable applications, where the detector's location should be changed frequently.

Although designed mainly for portable use, The SRS-202 can be fixed permanently to a horizontal surface, using the two screw holes at its bottom. It can also be fixed to a vertical surface, provided that a very strong adhesive is used.

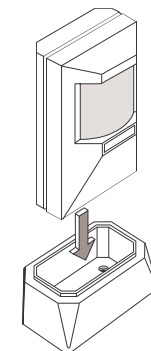

Figure 11. SRS-202

4. NOTES AND WARNINGS

4.1 Product Limitations

Visonic Ltd. wireless systems are reliable and are tested to high standards. However, due to the low transmitting power (required by the FCC and other regulatory authorities), there are some limitations to be considered:

- A. A receiver may be blocked by radio signals sent on or near its operating frequency, regardless of the digital code used.
- B. A receiver responds to one transmitted signal at a time.
- C. Wireless equipment should be tested regularly (at least once a week) to discover sources of interference and to protect against faults.

4.2 Compliance with Standards

WARNING! Changes or modifications to this unit not expressly approved by the party responsible for compliance could void the user's authority to operate the equipment.

This device complies with FCC Rules Part 15. Operation is subject to two conditions: (1) This device may not cause harmful interference, and (2) this device must accept any interference that may be received or that may cause undesired operation.

This device complies with the European Council Directive EMC 89/336/EEC & 92/31/EEC and bears the CE mark and certification.

APPENDIX A. THE VISONIC LTD. POWERCODE SYSTEM

A-1. The PowerCode Message Format

The PowerCode message transmitted by the MCPIR-2000 includes the detector's 24-bit ID and a status report (see Fig. A1).

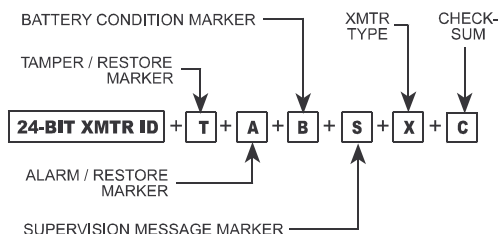

Figure A1. Transmitted Data

A message includes the following data:

Detector's ID: Any message transmitted starts with the 24-bit ID assigned to the particular detector unit.

Tamper / Restore: Upon removal of the unit's front cover, a message will be transmitted with a "tamper marker" ON. If the unit's cover is put back, a message will be transmitted with the tamper marker OFF ("Tamper Restore").

Alarm: Once the detector is in alarm, a message will be transmitted with an "Alarm marker" ON.

Low Battery: A special battery condition marker is used to report the battery status in any message. The battery is tested once an hour and if found low, the "low battery marker" is set to ON in all following messages.

Supervision Message: A special "supervision message marker", when set to ON, identifies the periodic supervision

messages transmitted automatically at 1 hour intervals. This marker will be OFF in all other messages.

Transmitter Type: A special marker indicates the type of the transmitter:

Supervised or non-supervised

Reports or does not report restorals after alarm

The MCPIR-2000 is supervised and does not report restorals after alarms.

Checksum: Checksum bits at the end of the message allow the receiver to determine whether an incoming message is valid (error-free). This feature considerably upgrades the reliability of the wireless communication link.

A-2. Anti-Collision

To overcome message collisions at the receiving end, PowerCode transmitters transmit 3 data bursts at random intervals, with 6 repetitions of the same message in each burst (Fig. A2). This redundancy improves the probability of reception.

Note: Periodic supervision messages are an exception to this rule - they consist of a single 6-message burst.

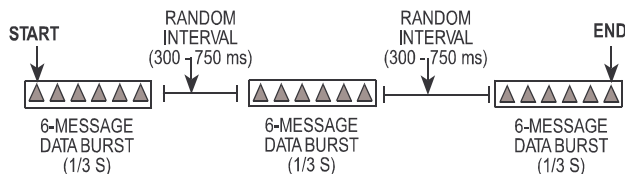

Figure A2. Anti-Collision Transmission Sequence

WARRANTY

Visonic Ltd. and/or its subsidiaries and its affiliates ("the Manufacturer") warrants its products hereinafter referred to as "the Product" or "Products" to be in conformance with its own plans and specifications and to be free of defects in materials and workmanship under normal use and service for a period of twelve months from the date of shipment by the Manufacturer. The Manufacturer's obligations shall be limited within the warranty period, at its option, to repair or replace the product or any part thereof. The Manufacturer shall not be responsible for dismantling and/or reinstallation charges. To exercise the warranty the product must be returned to the Manufacturer freight prepaid and insured.

This warranty does not apply in the following cases: improper installation, misuse, failure to follow installation and operating instructions, alteration, abuse, accident or tampering, and repair by anyone other than the Manufacturer.

This warranty is exclusive and expressly in lieu of all other warranties, obligations or liabilities, whether written, oral, express or implied, including any warranty of merchantability or fitness for a particular purpose, or otherwise. In no case shall the Manufacturer be liable to anyone for any consequential or incidental damages for breach of this warranty or any other warranties whatsoever, as aforesaid.

This warranty shall not be modified, varied or extended, and the Manufacturer does not authorize any person to act on its behalf in the modification, variation or extension of this warranty. This warranty shall apply to the Product only. All products, accessories or attachments of others used in conjunction with the Product, including batteries, shall be covered solely by their own warranty, if any. The Manufacturer shall not be liable for any damage or loss whatsoever, whether directly, indirectly, incidentally, consequentially or otherwise, caused by the malfunction of the Product due to products, accessories, or attachments of others, including batteries, used in conjunction with the Products.

The Manufacturer does not represent that its Product may not be compromised and/or circumvented, or that the Product will prevent any death, personal and/or bodily injury and/or damage to property resulting from burglary, robbery, fire or otherwise, or that the Product will in all cases provide adequate warning or protection. User understands that a properly installed and maintained alarm may only reduce the risk of events such as burglary, robbery, and fire without warning, but it is not insurance or a guarantee that such will not occur or that there will be no death, personal damage and/or damage to property as a result.

The Manufacturer shall have no liability for any death, personal and/or bodily injury and/or damage to property or other loss whether direct, indirect, incidental, consequential or otherwise, based on a claim that the Product failed to function. However, if the Manufacturer is held liable, whether directly or indirectly, for any loss or damage arising under this limited warranty or otherwise, regardless of cause or origin, the Manufacturer's maximum liability shall not in any case exceed the purchase price of the Product, which shall be fixed as liquidated damages and not as a penalty, and shall be the complete and exclusive remedy against the Manufacturer.

Warning: The user should follow the installation and operation instructions and among other things test the Product and the whole system at least once a week. For various reasons, including, but not limited to, changes in environmental conditions, electric or electronic disruptions and tampering, the Product may not perform as expected. The user is advised to take all necessary precautions for his /her safety and the protection of his/her property.

6/91



W.E.E.E. Product Recycling Declaration

For information regarding the recycling of this product you must contact the company from which you originally purchased it. If you are discarding this product and not returning it for repair then you must ensure that it is returned as identified by your supplier. This product is not to be thrown away with everyday waste.

Directive 2002/96/EC Waste Electrical and Electronic Equipment.



VISONIC LTD. (ISRAEL): P.O.B 22020 TEL-AVIV 61220 ISRAEL. PHONE: (972-3) 645-6789. FAX: (972-3) 645-6788

VISONIC INC. (U.S.A.): 65 WEST DUDLEY TOWN ROAD, BLOOMFIELD CT. 06002-1911. PHONE: (860) 243-0833, (800) 223-0020 FAX: (860) 242-8094

VISONIC LTD. (UK): FRASER ROAD, PRIORY BUSINESS PARK, BEDFORD MK44 3WH. PHONE: (0870) 7300800 FAX: (0870) 7300801

INTERNET: www.visonic.com

©VISONIC LTD. 2002 MCPIR-2000 D-3600-0 NEW: DE3600- (REV. 2, 7/02)



MADE IN ISRAEL