

CLIP MCW

Wireless Curtain-Type PowerCode Infrared Detector



Visonic

Installation Instructions

1. INTRODUCTION

The CLIP MCW is the smallest and most elegant wireless curtain-pattern PIR detector for indoor use and designed for easy installation. Its function is based on new and sophisticated, patented FM data acquisition and digital signal processing.

Modern technology is used to include 3 different detectors in a single case, each programmable for optimized performance at the specific mounting location. This results in better catch performance and virtually no false alarms.

The superiority in performance of this detector is achieved by applying an improved version of the patented **True Motion Recognition™** (TMR) algorithm. This advanced motion analysis method allows the CLIP MCW to distinguish between the true motion of the human body and any other disturbances that cause false alarms.

After detection, the detector disarms itself to save battery power. It rearms (reverts to the ready state) if there is no subsequent detection throughout the following 2-minute period.

The CLIP MCW includes the following features:

- Very low current consumption
- Microprocessor-controlled temperature compensation
- Sealed chamber protects the optical system
- Front cover tamper switch
- Back tamper switch (optional)
- White light protection
- Elegantly styled, sturdy case

Detailed coverage patterns and mounting alternatives are illustrated in Figures 2 through 6.

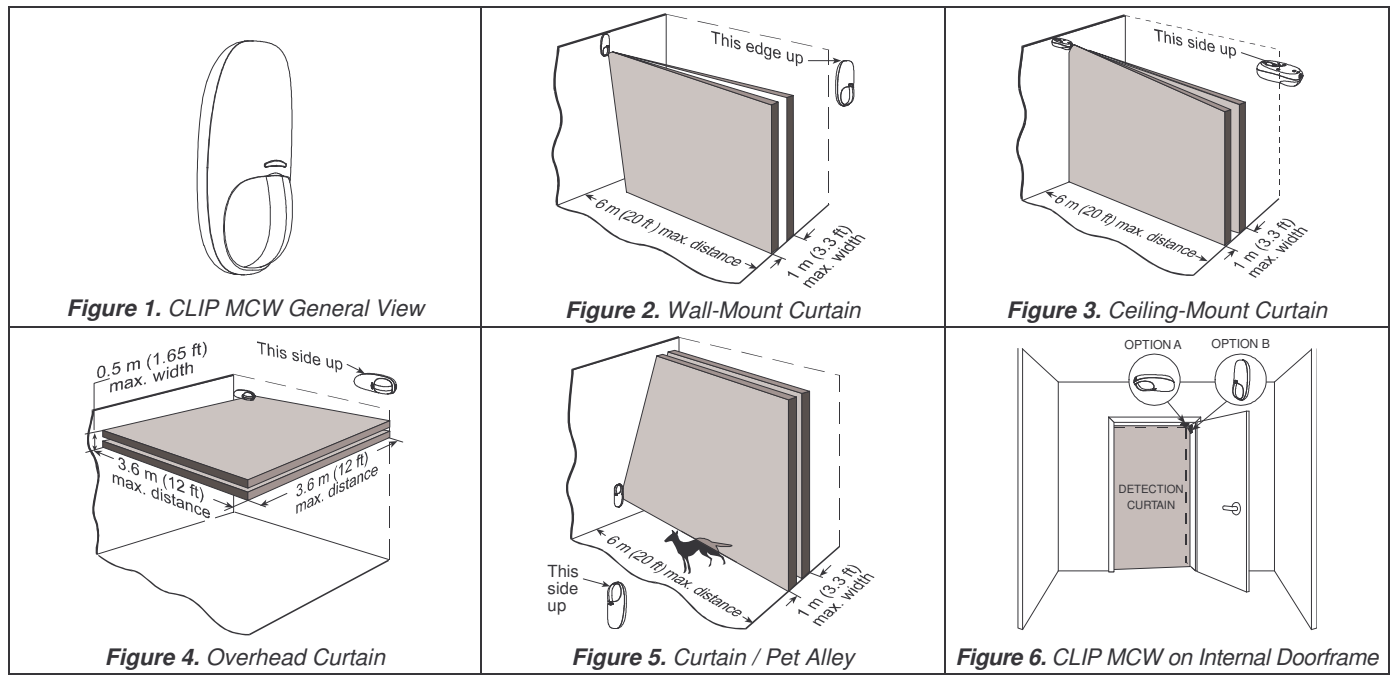

2. SPECIFICATIONS

OPTICAL

Detector Type: Dual-element low noise pyroelectric sensor.

Number of Curtain Beams: 2

Mounting Positions: See Figures 2 through 6.

Range Settings: Long (6 m), Medium (4 m) and Short (2 m). (Jumper-selected)

ELECTRICAL

Internal Battery: 3V Lithium battery, type CR123A. For UL installations, use Panasonic or Sanyo only.

Nominal Battery Capacity: 1450 mA/h.

Battery Life (with LED on): 3 years (for typical use).

Battery Power Test: Performed immediately upon battery insertion and periodically every several hours.

Microprocessor: 8-bit, low power CMOS.

FUNCTIONAL

Visual Indications:

LED Lights for about 3 seconds upon transmission of alarm & tamper messages and upon motion detection in the walk test mode.

LED Flashes during the power-up stabilization period (approx. 2 min), or after restoring the cover (by pressing the tamper switch).

LED Does not light upon transmission of supervision messages.

Alarm Period: Approx. 3 seconds.

Rearm Timer: Rearms the detector 2 minutes after the last alarm.

WIRELESS

Frequency (MHz): 315 (U.S. version), 433.92, 868.95, 869.2625 or other frequency according to local requirements.

Transmission Sequence: 3 data bursts at variable intervals within 3 seconds.

Encoding: 24-bit ID, over 16 million possible combinations.

Total Message Length: 36 bits.

Tamper Alert: Reported when a tamper event occurs and in any subsequent message, until the tamper switch is restored.

Supervision Message: Signaling at 60-minute intervals (U.S. version), 15 minute intervals (UK version), or according to the local standards.

MOUNTING

Height: 1.8 - 2.4 m (6 - 8 ft).

Installation Options: See Figures 9 through 13.

ENVIRONMENTAL

Operating Temperature: -10 °C to 50 °C (14 °F to 122 °F).

Storage Temperature: -20 °C to 60 °C (-4 °F to 140 °F).

RFI Protection: > 20 V/m to 1000 MHz.

PHYSICAL
Dimensions (H x W x D): 105 x 35 x 30 mm (4-1/8 x 1-3/8 x 1-3/16 in.).
Weight (with battery): 60 g (2.1 oz).

Color: White.
PATENTS
 U.S. Patent 5,693,943 (other patents pending)

3. INSTALLATION

3.1 General Guidelines

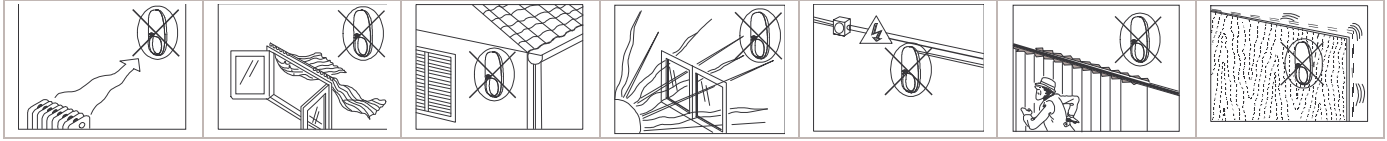

3.2 Regular Mounting

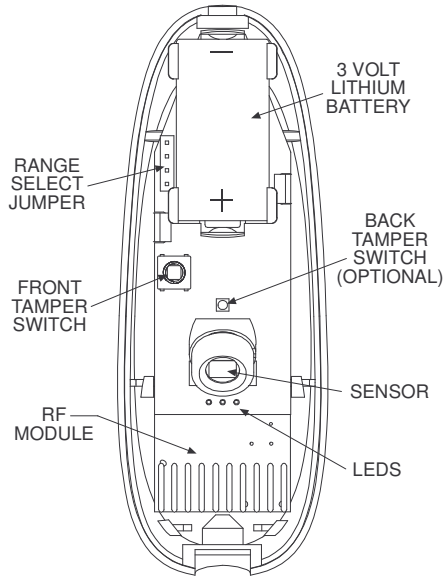

Figure 7. Internal View

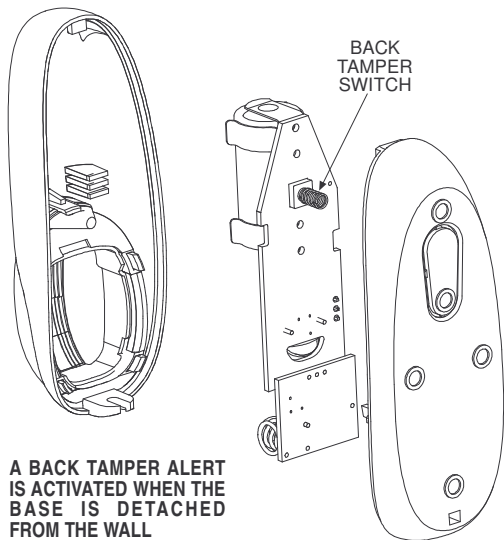

Figure 8. Back Tamper (Rear) View

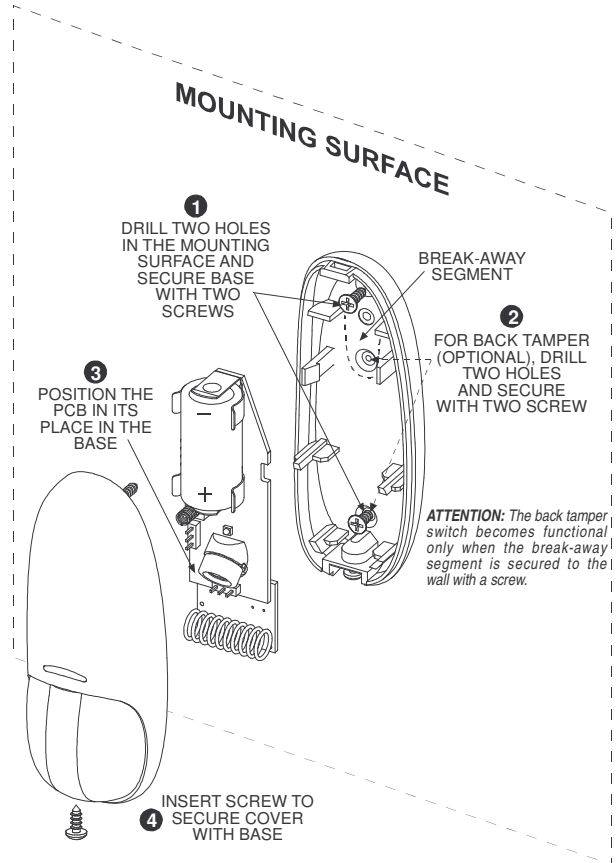

Figure 9. Surface Mounting

Notes:

- 1) After mounting, be sure that no gaps remain in the detector housing. For example, in the area around the screw holes.
- 2) Remove the battery using your fingers, and not with a screwdriver.

3.3 Bracket Mounting

Note: When mounting using the bracket, the back tamper is not functional.

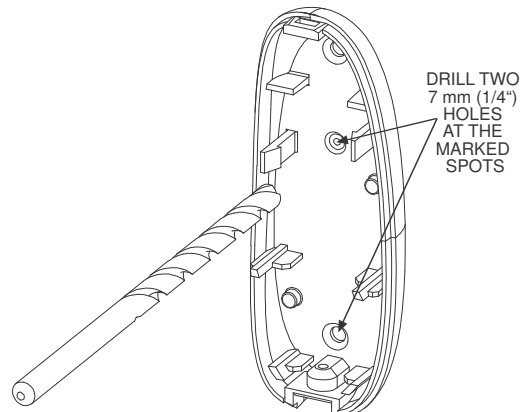

Figure 10. Drilling Holes

NOTE: THE BRACKET PROVIDES TWO MOUNTING OPTIONS FOR OPTIMUM ANGLE COVERAGE.

* USE THESE TWO HOLES TO INCREASE THE COVERAGE RANGE BY 5°

** USE THESE TWO HOLES TO INCREASE THE COVERAGE RANGE BY 10°

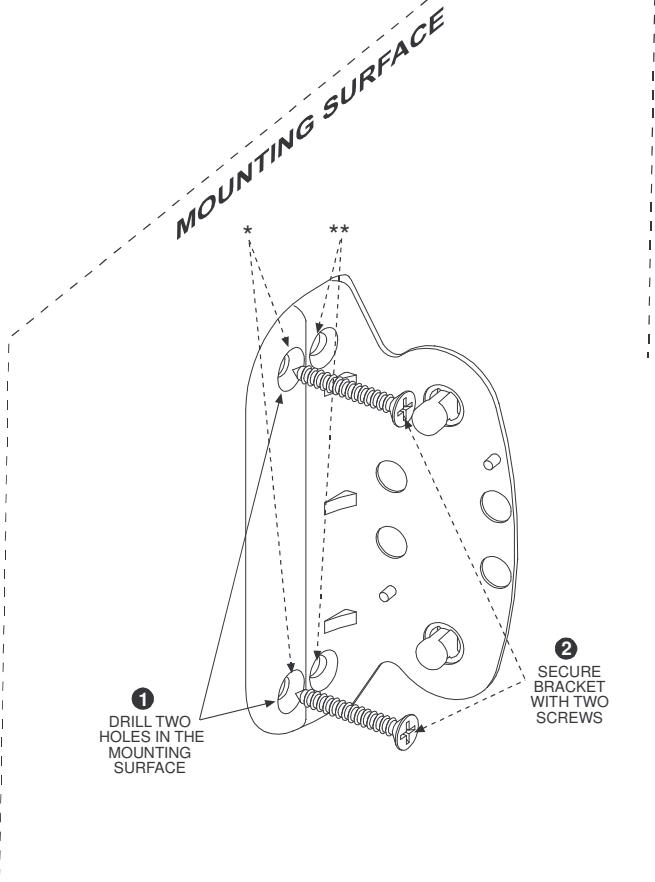

Figure 11. Mounting Bracket to Surface

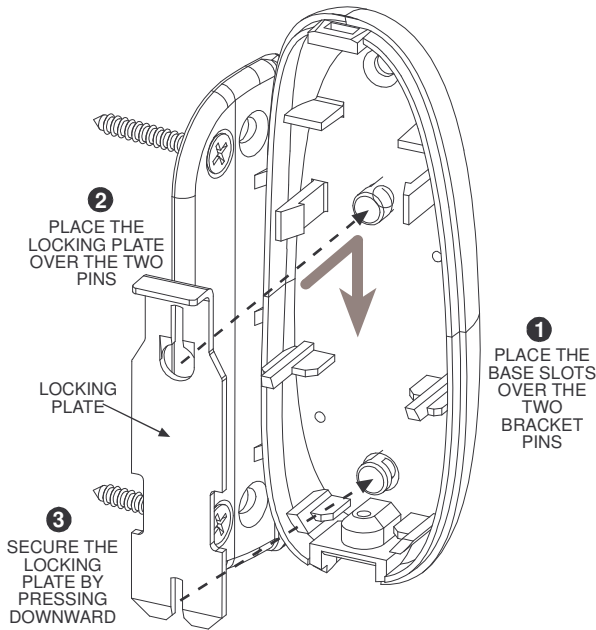

Figure 12. Securing Locking Plate to Base

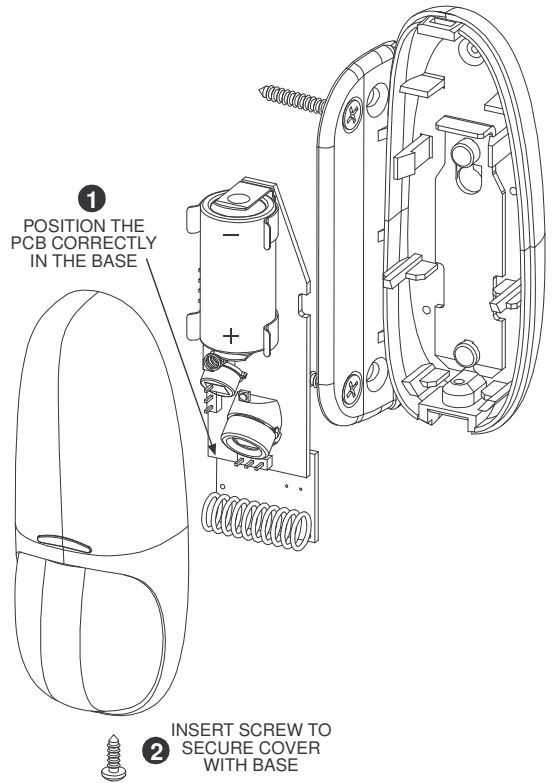
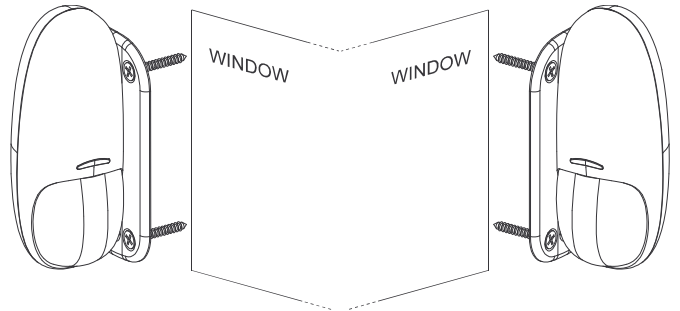

Figure 13. Mounting Cover to Base



Note: The CLIP MCW can be mounted on either side of a window.

Figure 14. Mounting on Both Sides of a Window

3.4 Setting the Coverage Range

A 4-pin jumper is used to select 3 ranges, according to the type of installation, for the curtain beams (see Figures 7 and 15).

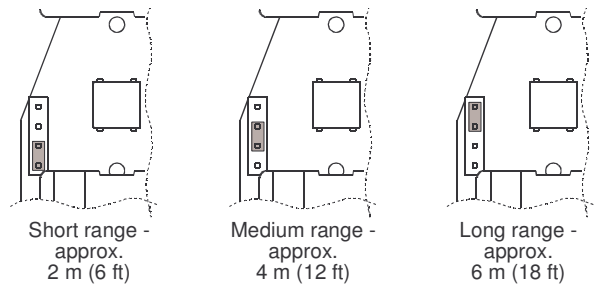

Figure 15. Range Jumper Settings

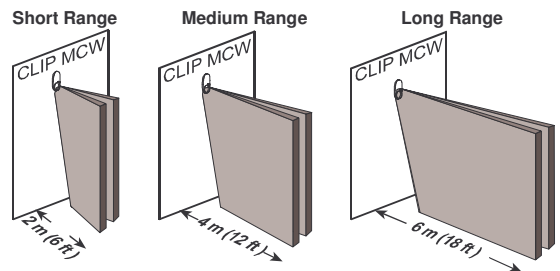

Figure 16. Range Setting Diagram

The purpose of the range setting is to ensure optimal signal processing and high immunity against false alarms.

Mount the range jumper in the desired position and make sure that the protected area is within the selected coverage range (see figure 16). Carry out a walk test (refer to Para. 3.5) to verify proper performance.

3.5 Walk Testing

A. Mount the cover and tighten the screw. Wait for the detector to stabilize (the LED stops flashing approx. two minutes after the cover is closed).

B. Walk slowly across the far end of the curtain pattern (in opposite directions). The LED indicator lights for approx. 3 seconds whenever you enter or exit a curtain beam.

Important: Perform walk test at least once a week to assure proper function of the detector.

Note: After closing the cover the detector enters a 15 minute walk-test mode. In this mode the LED will flash each time a detection occurs, regardless of LED jumper settings, and the detector will transmit on the occurrence of each detection event.

4. SPECIAL COMMENTS

4.1 Product Limitations

Visonic Ltd. wireless systems are very reliable and are tested to high standards. However, due to their low transmitting power and limited range (required by FCC and other regulatory authorities), there are some limitations to be considered:

- A. Receivers may be blocked by radio signals on or near their operating frequencies, regardless of the code selected.
- B. A receiver can only respond to one signal at a time.
- C. Wireless equipment should be tested regularly to determine whether there are sources of interference and to protect against faults.
- D. Even the most sophisticated detectors can sometimes be defeated or may fail to warn due to: DC power failure / improper connection, malicious masking of the lens, tampering with the optical system, decreased sensitivity in ambient temperatures near that of the human body and unexpected failure of a component part.
The above list includes the most common reasons for failure to detect intrusion, but is by no means comprehensive. It is therefore recommended that the detector and the entire alarm system be checked weekly, to ensure proper performance.
- E. An alarm system should not be regarded as a substitute for insurance. Home and property owners or renters should be prudent enough to continue insuring their lives and property, even though they are protected by an alarm system.

4.2 Compliance with Standards

The 315 MHz version of this device complies with Part 15 of the FCC Rules. Operation is subject to the following two conditions: (1) This device may not cause harmful interference, and (2) This device must accept any interference received, including interference that may cause undesired operation.

WARNING! Changes or modifications to this unit not expressly approved by the party responsible for compliance could void the user's authority to operate the equipment.

The digital circuit of this device has been tested and found to comply with the limits for a Class B digital device, pursuant to Part 15 of the FCC Rules. These limits are designed to provide reasonable protection against harmful interference in residential installations. This equipment generates uses and can radiate radio frequency energy and, if not installed and used in accordance with the instructions, may cause harmful interference to radio and television reception. However, there is no guarantee that interference will not occur in a particular installation. If this device does cause such interference, which can be verified by turning the device off and on, the user is encouraged to eliminate the interference by one or more of the following measures:

- Re-orient or re-locate the receiving antenna.
- Increase the distance between the device and the receiver.
- Connect the device to an outlet on a circuit different from the one which supplies power to the receiver.
- Consult the dealer or an experienced radio/TV technician.

4.3 Frequency Allocations for Wireless Devices in European (EU) Countries

- 315 MHz is not allowed in any EU member state.
- 433.92 MHz has no restriction in any EU member state.
- 868.95 MHz (wide band) is allowed in all EU member states.
- 869.2625 MHz (narrow band) is not restricted in any EU member state.

WARRANTY

Visonic Ltd. and/or its subsidiaries and its affiliates ("the Manufacturer") warrants its products hereinafter referred to as "the Product" or "Products" to be in conformance with its own plans and specifications and to be free of defects in materials and workmanship under normal use and service for a period of twelve months from the date of shipment by the Manufacturer. The Manufacturer's obligations shall be limited within the warranty period, at its option, to repair or replace the product or any part thereof. The Manufacturer shall not be responsible for dismantling and/or reinstallation charges. To exercise the warranty the product must be returned to the Manufacturer freight prepaid and insured.

This warranty does not apply in the following cases: improper installation, misuse, failure to follow installation and operating instructions, alteration, abuse, accident or tampering, and repair by anyone other than the Manufacturer.

This warranty is exclusive and expressly in lieu of all other warranties, obligations or liabilities, whether written, oral, express or implied, including any warranty of merchantability or fitness for a particular purpose, or otherwise. In no case shall the Manufacturer be liable to anyone for any consequential or incidental damages for breach of this warranty or any other warranties whatsoever, as aforesaid.

This warranty shall not be modified, varied or extended, and the Manufacturer does not authorize any person to act on its behalf in the modification, variation or extension of this warranty. This warranty shall apply to the Product only. All products, accessories or attachments of others used in conjunction with the Product, including batteries, shall be covered solely by their own warranty, if any. The Manufacturer shall not be liable for any damage or loss whatsoever, whether directly, indirectly, incidentally, consequentially or otherwise, caused by the malfunction of the Product due to products, accessories, or attachments of others, including batteries, used in conjunction with the Products.

The Manufacturer does not represent that its Product may not be compromised and/or circumvented, or that the Product will prevent any death, personal and/or bodily injury and/or damage to property resulting from burglary, robbery, fire or otherwise, or that the Product will in all cases provide adequate warning or protection. User understands that a properly installed and maintained alarm may only reduce the risk of events such as burglary, robbery, and fire without warning, but it is not insurance or a guarantee that such will not occur or that there will be no death, personal damage and/or damage to property as a result.

The Manufacturer shall have no liability for any death, personal and/or bodily injury and/or damage to property or other loss whether direct, indirect, incidental, consequential or otherwise, based on a claim that the Product failed to function. However, if the Manufacturer is held liable, whether directly or indirectly, for any loss or damage arising under this limited warranty or otherwise, regardless of cause or origin, the Manufacturer's maximum liability shall not in any case exceed the purchase price of the Product, which shall be fixed as liquidated damages and not as a penalty, and shall be the complete and exclusive remedy against the Manufacturer.

Warning: The user should follow the installation and operation instructions and among other things test the Product and the whole system at least once a week. For various reasons, including, but not limited to, changes in environmental conditions, electric or electronic disruptions and tampering, the Product may not perform as expected. The user is advised to take all necessary precautions for his/her safety and the protection of his/her property.

6/91



W.E.E. Product Recycling Declaration

For information regarding the recycling of this product you must contact the company from which you originally purchased it. If you are discarding this product and not returning it for repair then you must ensure that it is returned as identified by your supplier. **This product is not to be thrown away with everyday waste.** Directive 2002/96/EC Waste Electrical and Electronic Equipment.



VISONIC LTD (ISRAEL): P.O.B 22020 TEL-AVIV 61220 ISRAEL. PHONE: (972-3) 645-6789, FAX: (972-3) 645-6788
VISONIC INC. (U.S.A.): 65 WEST DUDLEY TOWN ROAD, BLOOMFIELD CT. 06002-1911. PHONE: (860) 243-0833, (800) 223-0020 FAX: (860) 242-8094
VISONIC LTD. (UK): FRASER ROAD, PRIORY BUSINESS PARK, BEDFORD MK44 3WH. PHONE: (0870) 7300800 FAX: (0870) 7300801
INTERNET: www.visonic.com

©VISONIC LTD. 2004 CLIP MCW DE3594- (REV. 1, 12/04).



MADE IN ISRAEL